



HIGHLIGHTS

- Three speeds ceiling mounted fan that's designed to operate continuously and quietly.
- It is also ETL and cETL certified to comply with ASHRAE 62.2 whole house fan to meet the minimum ventilation required by local building codes.
- Three speeds EC motor fan with low energy consumption.
- Wall mount speed controller switch for CFM adjustment.
- CFM select setting for high speed (200CFM-250CFM-300CFM)
- QUIET operates at lower rpm to ensure low sone levels.
- Power rating 120 volts and 60 Hz.

SPECIFICATIONS

Model	ODD-300-3					
Static Pressure	0.1	0.25	0.1	0.25	0.1	0.25
Air Volume (CFM)	200	173	250	217	300	270
Noise (sones)	2.0	N/A	3.0	N/A	0.4	N/A
Fan Watts	25.2W		39W		52W	
Duct Diameter	6"					
Power Rating (V/Hz)	120/60					

DIMENSIONS

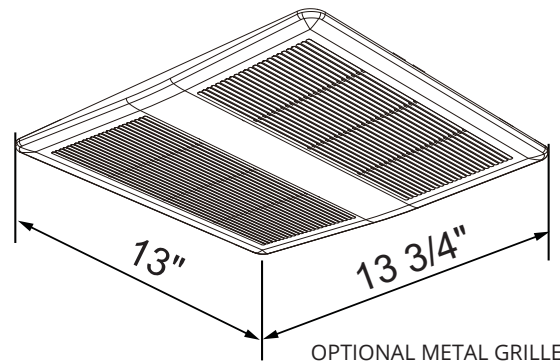
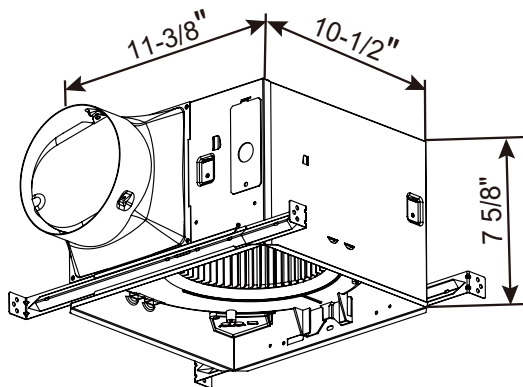

HOUSING

- Made of rugged 26 gauge galvanized steel.
- Detachable 6 inch collar which include a lightweight built in back draft damper.
- Heavy duty 4 point mounting bracket adjustable up to 24 inches from centre.



GRILLE

- Made of a rugged polymeric resin that's known for it's durability.
- Premium grille offers low profile with elegance and simplicity.
- Comes with torsion spring clips for easy installation.

Switch position			
Airflow (CFM)	200	250	300

TESTING REPORT

- HVI Certified performance based on HVI Procedures 915, 916, and 920.

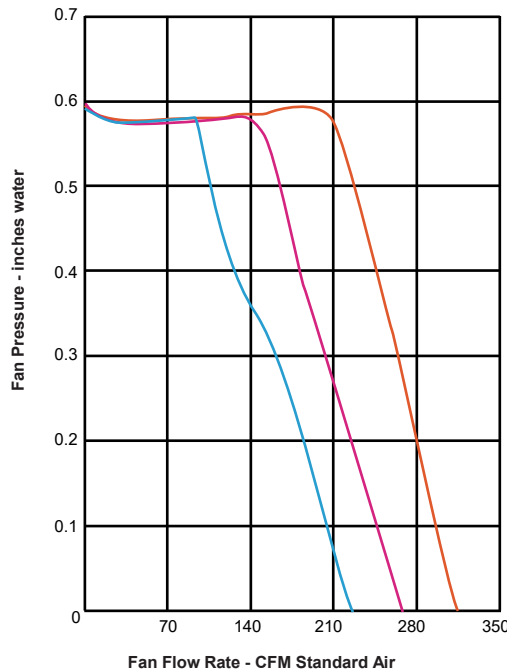

- Other airflow reference performance based on HVI Procedures 915, 916, and 920.

Reference	QTY.	Remarks	Project:
			Location:
			Architect:
			Engineer:
			Contractor:
			Submitted by:
			Date:

ORTECH reserves the right to modify at any time, without notice, any or all of our product's features, designs, components and specifications to meet market changes.